

TECALEMIT



Lubrication Equipment Solutions



Corporate Profile

Tecalemit has been a name synonymous with lubrication equipment in Australia for over sixty years. Famous for pumps, grease guns and automatic lubrication systems, Tecalemit is also one of Australia's most trusted manufacturers and importers of vehicle hoists and garage equipment.

This catalogue profiles products in the lubricant dispensing equipment range, including a variety of products from Tecalemit's strategic supply partner RAASM sPa. RAASM is Europe's leading manufacturer of lubrication equipment for automotive workshops, with a range of complementary products ranging from waste oil handling equipment to air operated pumps and hose reels. Tecalemit blend the RAASM and Tecalemit ranges in a variety of lubrication equipment solutions for customers in a range of industries including automotive, mining, transport, manufacturing, primary production and agriculture.

Whether it is handling waste oil from vehicles to drums for small workshops, or ensuring the right amount of grease gets to the right place at the right time in a mining mill, Tecalemit's lubrication equipment solutions help you get the job done safely, efficiently and conveniently.

[WWW.TECALEMIT.COM.AU](http://www.tecalemit.com.au)



Tecalemit's reputation is built on reliability and value for money based on robust engineering and product durability, designed to withstand the toughest working environments. Innovative problem solving skills, certified quality management systems, the backing of a large publicly owned parent company and a genuine commitment to customer satisfaction make

Tecalemit a preferred supplier to many of Australia's largest companies and leading distributors.

For more detailed information on Tecalemit, or our range of vehicle hoists and centralised lubrication equipment solutions, visit our website -

www.tecalemit.com.au

or contact us directly via e-mail or phone as listed on the rear cover of this catalogue.

Contents

Waste Oil Handling Equipment	2
Air Operated Oil Pumps & Diaphragm Pumps	4
Air Operated Grease Pumps	6
Trolleys and Trolley Kits	8
RAASM Hose Reels	9
Oil, Grease Meters and Control Valves	11
IBC Solutions	12
OilPro Oil Management System	14
Installation Accessories	15
Parts Washers	17
Grease, Oil Guns and Accessories	18
Grease Nipples and Assortments	20
Diesel Fuel Handling Equipment	22
Hand Pumps	24

For more information

A more detailed data sheet on any product can be obtained from our website,

www.tecalemit.com.au



www.tecalemit.com.au

TECALEMIT

Waste Oil Handling Equipment

Pedestal Oil Drainers

Tecalemit's Pedestal or Wineglass style oil drainers are the originals and the best of their type. Proven engineering, first class materials, precision manufacturing and our certified quality systems make these units superior to cheap imitations in terms of reliability and performance.

Product Code	Description	Shipping Dimensions	
Wine Glass Drainer V2750	Tecalemit's original wineglass oil drainer is designed for simple and efficient waste oil collection and disposal. Heavy duty galvanised round steel bowl, 1.2-1.9 metre telescopic stand with reliable lock. 14 Litre bowl assembly includes precision machined brass drain check valve and removable strainer. 2" cast iron waste oil drum adaptor included.	Quantity -1 Weight -10kg Size (cm) - 100 x 55 x 60	
ATF Drainer V2750AT	Based on the same pedestal and accessories as the wineglass drainer, Tecalemit's ATF pedestal drainer features a large heavy duty ABS bowl, 20 Litre capacity and 450x450mm square to catch all the pan drips.	Quantity -1 Weight -11kg Size (cm) - 110 x 50 x 60	
Replacement Bowl Assemblies Wineglass V2755	Wineglass bowl assembly, including valve and strainer.	Quantity - 1 Weight -3.5kg Size (cm) -50 x 30 x 50	
ATF V2755AT	ATF drainer bowl assembly including valve and strainer.	Quantity -1 Weight -3.5kg Size (cm) -50 x 20 x 50	
Bung Adaptor V2770	Cast iron drum adaptor is fitted to your waste oil tank or drum to take the wineglass drainer bowls. Built in spigot automatically opens drain valve.	Quantity -1 Weight -0.6kg Size (cm) -7 x 7 x 4	
Seal Kit V2757	Drain valve seal.	Quantity -1 Weight -0.3kg Size (cm) -10 x 10 x 10	

Waste Oil Drainer for Drums

Waste Oil Drainer for Drums 42000	Combines the convenience of a height adjustable wide profile rotating bowl and anti splash screen, with a mobile drum trolley so you can drain oil directly into waste drums. Eliminates double handling for small workshops who store waste oil in drums.	Quantity -1 Weight -29kg Size (cm) -100 x 100 x 15	
---	--	--	---

Low Profile Floor and Pit Waste Oil Drainers

Low Profile Floor Drainer 95 Litre 42073	Low profile wheel mounted floor drainer for truck workshops or where a hoist or pit is not available. Features anti splash screen, fold away push bar & vacuum transfer pump kit.	Quantity- 1 Weight -19kg Size (cm) -80 x 23 x 51	
Waste Oil Drainer for Pits 65 Litre 42060	Pit mounted 65 Litre capacity waste oil drainer with adjustable roller arms, anti splash screen and removable splash tray. Bottom draining with ball check valve. Optional quick connect and vacuum transfer pump kit available.	Quantity -1 Weight -27kg Size (cm)- 75 x 60 x 22	

Waste Oil Suction Pump

Waste Oil Suction Pump 33125	1:1 ratio wall mounted vacuum pump for transferring waste oil from pit and floor drainers to waste oil storage tanks. Quick connect fittings for vacuum pump hose fitted to hose.	Quantity -1 Weight- 8.4kg Size (cm)- 50 x 25 x 5	
Hose Fittings Female 33126 Male 33127	Fitted to drainer.	Quantity -1 Weight -0.1kg Size (cm) -10 x 10 x 10	

Continued...



Mobile Waste Oil Drainers

RAASM mobile waste oil drainers are designed to collect, store and carry waste oil and coolant from the service bay to bulk waste oil storage. Practical design including oversize drain bowls, sight gauges and integrated drain hoses minimise the risk of operator exposure and spillage. Reservoirs are available in a range of convenient sizes and equipped for quick emptying with low pressure air.

Product Code	Description	Shipping Dimensions	
Mobile Waste Oil Drainers 65 Litre 42065 90 Litre 42090	Mobile waste oil drainers featuring 65 or 90 Litre reservoirs fitted with height adjustable wide profile rotating bowls incorporating anti splash screens. Reservoir is fitted with tool tray, sight level gauge, 2 metre drain hose and 0.5 bar pressure relief valve for air pressure discharge in 2-3 minutes.	Quantity 1 Weight 34kg Size (cm) 140 x 60 x 60	

Waste Oil Evacuators

RAASM waste oil evacuators take oil draining convenience and efficiency to the next level, by sucking hot oil from engines and transmissions via the dipstick tube. The mobile reservoirs act as vacuum receivers operated by simple venturi and flow control valves. This allows the unit to be vacuum charged and emptied at will, and used independently of the air supply. Not having to lift vehicles or remove plugs increases efficiency. Suction volume 1.5-2 Litres per minute using 6mm probe at oil temp 70-80 Degrees C. Ideal for marine engines and other industrial plant.

Mobile Waste Oil Evacuator 24 Litre 43024	24 Litre capacity ideal for small workshops and portability. Includes 2 metre suction hose and a variety of suction probes to suit most vehicles and plant types.	Quantity -1 Weight -14kg Size (cm)- 28 x 28 x 90	
Mobile Waste Oil Evacuator with Inspection Chamber 65 Litre 43065 90 Litre 43091	65 and 90 Litre capacity mobile oil evacuators for larger workshops includes 2m suction and drain hoses, suction probes, and 8 Litre oil inspection chamber to allow visual inspection of oil. Low pressure air discharge in 2-3 minutes.	Quantity -1 Weight -36kg Size (cm) -64 x 64 x 140	
Mobile Waste Oil Evacuator 65 Litre 43760	65 Litre capacity oil evacuator for marine and industrial applications includes 4m suction hose, suction probes and connection kit for inboard and outboard engines.	Quantity -1 Weight -28kg Size (cm) -60 x 60 x 90	

Combination Waste Oil Drainer/Evacuators

Combination Oil Evacuator/Drainer 65 Litre 44060 90 Litre 44090	65 and 90 Litre mobile evacuator/drainers combine convenience and efficiency of gravity draining or air evacuation. Includes wide profile drain bowl with anti splash screen, 2 metre suction and drain hoses, suction probes and reservoir mounted tool tray.	Quantity -1 Weight- 38kg Size (cm) -140 x 64 x 64	
Pantograph Oil Evacuator/Drainer 115 Litre 46215	The 115 Litre capacity 'pantograph' drainer is designed for truck workshops where vehicles are serviced in bays without pits or hoists. The pantograph mounted drain tray can be used at floor level or raised and is emptied by gravity when raised or vacuum when lowered. The unit doubles as an evacuator with a set of suction probes and 2m suction and drain hoses included.	Quantity -1 Weight -69kg Size (cm) -60 x 60 x 160	





Brake and Clutch Bleeder

Brake and Clutch Bleeder inc. Plug Set 10805 Brake Fluid Recovery Tank 10801	Air operated power brake bleeder for draining hydraulic brake fluids. Pre-charged air reservoir pushes clean fluid through the brake system into drain reservoirs, pushing out old fluid without exposing new fluid to moisture laden air. Brake fluid reservoir capacity 5 Litres. Max. working pressure air 2 bar, fluid 10 bar. Kit includes reservoir with fluid level reserve indicator, 3 metre delivery hose with quick release connector and filter, 2 fluid drain recovery tanks and quick release connecting plug set to suit most vehicles.	Quantity -1 Weight -11kg Size (cm) -55 x 55 x 70	
---	--	--	---

Air Operated Oil Pumps & Diaphragm Pumps

1:1 Ratio Low Pressure Transfer Pumps

1:1 Ratio pumps are designed for transferring low viscosity products relatively short distances at low pressures. They are ideal for mounting in drums and servicing oil bars. For heavier gear oils and longer distances, or for servicing hose reels, higher pressure pumps are required.



Brand	RAASM	RAASM	RAASM	RAASM	RAASM	RAASM
Series	1:1 / 23	1:1 / 40	1:1 / 40	1:1 / 23	1:1	1:1
Product Code	33096	33161	33196	33061	33.101260	33.101160
Applications	205L bung	Extendable	205L bung	Extendable		
Air Con. cfm/m3 per min	8/0.2	10/0.3	10/0.3	8/0.2	400Lpm	1200Lpm
Max. Input Air Pressure kPa/*MPa/psi	800/116	800/116	800/116	800/116	2-6bar	2-6bar
Max. Output Pressure* kPa/*MPa/psi	800/116	800/116	800/116	800/116	8bar	8bar
Output Volume*	23 LPM	40 LPM	40 LPM	23 LPM	60LPM	160LPM
Air Inlet Connection	F 1/4" BSP	F 1/4" BSP	F 1/4" BSP	F 1/4" BSP	F1/4"BSP	F1/2"BSP
Fluid Outlet Connection	F 1/2" BSP	F 1/2" BSP	F 1/2" BSP	F 1/2" BSP	F3/4"BSP	F11/4"BSP
Max. Viscosity	SAE80	SAE140	SAE140	SAE80		
Shipping Weight/Volume	6kg/0.02m ³	5.5kg/0.04m ³	6.5kg/0.02m ³	4.5kg/0.01m ³	7Kg/0.02m ³	16Kg/0.032m ³
						

+Also available as stub pumps 33060 23lpm, 33160 40lpm.

* Footnote: Figures quoted are nominal and vary with viscosity, distance, air input pressure and volume.

3:1 Ratio Medium Pressure Pumps.

3:1 Ratio pumps are designed for handling low to medium viscosity fluids in small to medium sized dispensing systems involving single point dispensing through hose reels and end of hose meters.

Brand	RAASM	RAASM	RAASM
Series	3:1 / 14	3:1 / 14	3:1 / 14
Product Code	35160	35161	35196
Applications	Stub	Extendable	205L bung
Air Con. cfm/m3 per min	8/0.2	8/0.2	8/0.2
Max. Input Air Pressure kPa/*MPa/psi	800/116	800/116	800/116
Max. Output Pressure* kPa/*MPa/psi	2.4*/348	2.4*/348	2.4*/348
Output Volume*	14 LPM	14 LPM	14 LPM
Air Inlet Connection	F 1/4" BSP	F 1/4" BSP	F 1/4" BSP
Fluid Outlet Connection	F 1/2" BSP	F 1/2" BSP	F 1/2" BSP
Max. Viscosity	SAE140	SAE140	SAE140
Shipping Weight/Volume	3.8kg/0.01m ³	4.2kg/0.01m ³	5.7kg/0.02m ³
			

Continued...



5:1 Ratio Pumps

5:1 Ratio pumps are designed for medium to large systems moving higher viscosity oils longer distances through hose reels and end of hose dispensing meters and multiple dispensing points.

Brand Series Product Code Applications Air Con. cfm/m3 per min Max. Input Air Pressure kPa*/MPa/psi Max. Output Pressure* kPa*/MPa/psi Output Volume* Air Inlet Connection Fluid Outlet Connection Max. Viscosity	RAASM 5:1 / 18 36060 Stub 9/0.2 800/116 4.0*/580 18 LPM F 1/4" BSP F 1/2" BSP SAE250	RAASM 5:1 / 18 36061 Extendible 9/0.2 800/116 4.0*/580 18 LPM F 1/4" BSP F 1/2" BSP SAE250	RAASM 5:1 / 18 36096 205L bung 9/0.2 800/116 4.0*/580 18 LPM F 1/4" BSP F 1/2" BSP SAE250
Shipping Weight / Volume	4.1kg/0.01m3	4.2kg/0.01m3	5.4kg/0.02m3
			

7:1, 9:1 and 11:1 Ratio High Pressure High Volume Oil Pumps

RAASM series 900 7:1 and 11:1 ratio oil pumps deliver higher volume and pressure than RAASM's smaller 5:1 pumps and are recommended for large multiple point dispensing systems with long pipe runs or where multiple dispensing points are used simultaneously. RAASM series 1200 9:1 ratio oil pumps are designed to push viscous oils through long pipe runs, hose reels and end of hose dispensing meters. RAASM's 900 and 1200 series pumps are available in a variety of other models and ratios not shown below including 900 series 5:1 and 12:1 and 1200 series 6:1 and 18:1. Consult Tecalemit Technical Services on your specific needs.

Brand Series and Ratio Product Code Applications Air Con.* cfm/m3/min Max. Input Air Pressure kPa*/MPa/psi Max. Output Pressure* kPa*/MPa/psi Output Volume* Air Inlet Connection Fluid Outlet Connection Suction Tube Diameter Bung Adaptor Code (53mm) Shipping Weight/Volume	RAASM 900 7:1 91C/71 Drum/Stub 64/1.8 800/116 5.4*/783 30 LPM 1/2 BSPF 3/4 BSPF 53mm 10/15 16kg/0.06m3	RAASM 900 7:1 91F/71 Drum/Stub 64/1.8 800/116 5.4*/783 30 LPM 1/2 BSPF 3/4 BSPF 53mm 10/15 16kg/0.06m3	RAASM 900 11:1 91F/111 Drum 64/1.8 800/116 8.2*/1189 23 LPM 1/2 BSPF 3/4 BSPF 45mm 10/14 16kg/0.06m3	RAASM 1200 9:1 115F/91 Stub 113/3.2 800/116 6.2/899 45 LPM 1/2 BSPF 3/4 BSPF 62mm na 16kg/0.06m3
				



* Footnote: For wall mounting kits and accessories see page 9.

Note: 900 and 1200 'F' series pumps include flange and handles, 'C' series is a bare or 'mono-block' pump. 'D' series separated models are also available in stainless steel. *For detailed information on output volume and pressures consult performance curves on the product data sheet for that pump.

Air Operated Grease Pumps



Portable Grease Pail Kits

Mobile grease pumps are a safe, efficient and practical way to move grease in automotive workshops and industrial plants. Trolley mounted pumps are ideal for workshop and factory floor, while the porta-pump is ideal for service vehicle and field work.

Product Code	Description	Shipping Dimensions	
Portable Grease Pump 20kg 64031	Kit includes 20kg, 50:1 ratio grease pump, drum cover and follower with 4m hose, 'z' swivel and control valve with flexible extension.	Quantity -1 Weight -11kg Size (cm) -31 x 31 x 90	
Portable Grease Pump and Trolley 20kg 64035	Kit includes 20 or 55kg, 50:1 ratio grease pump, drum cover and follower with hose 'z' swivel and control valve with flex and trolley.	Quantity -1 Weight- 15kg Size (cm) -60 x 35 x 12	
55kg 64041		Quantity -1 Weight -21kg Size (cm) -68 x 68 x 100	

Grease Transfer Pumps 18:1 & 11:1

Series 1200 industrial air-operated pumps. Ideal for the transfer of medium/high-viscosity grease. The high quality of the components ensures lasting and reliable operation even in extreme conditions.

Compatible fluids	oils, lubricants and greases	oils, lubricants and greases	oil, lubricants and allied products	oil, lubricants and allied products
Series and Ratio	900 11:1	900 11:1	1200 18:1	1200 18:1
Product Code	90F.111	91F.111	115F.181	116F.181
Type of seals	polyurethane/PU	polyurethane/PU	polyurethane/PU	polyurethane/PU
Suction tube upper body	aluminium	aluminium	carbon steel	carbon steel
suction tube	carbon steel	carbon steel	carbon steel	carbon steel
Air inlet connection	F1/2"	F 1/2"	F1/2"	F1/2"
Fluid outlet connection	F3/4"	F 3/4"	F3/4"	F3/4"
suction tube length	480mm	940 mm	480mm	940 mm
suction tube diameter	ø 45	ø 45	ø 45	ø 45
Max. air consumption 8 bar	1,7 m3/min	1,7 m3/min	2,8 m3/min	2,8 m3/min
Noise level	80 dB	80 dB	80 dB	80 dB
Air max. feed pressure	8 bar	8 bar	8 bar	8 bar
	No 1 packing m³ 0,040 11 Kg	No 1 packing m³ 0,070 16Kg	No. 1 packing m³ 0,045 15.5 Kg	No, 1 packing m³ 0,070 18 Kg
				

High Pressure Grease Pumps

50:1 & 65:1 Series High Pressure Grease Pumps – RAASM



RAASM 50:1 ratio grease pumps are high pressure medium output grease pumps suited to small and medium sized workshop dispensing installations and centralised grease lubrication systems.

Brand Series	RAASM 600 / 50:1	RAASM 700 / 65:1	RAASM 600 / 50:1	RAASM 700 / 65:1	RAASM 600 / 50:1	RAASM 700 / 65:1	
Product Code	62048	63048	62074	63074	62095	63095	
Applications	20Kg	20Kg	55Kg	55Kg	18Kg	180Kg	
Air Con. cfm/m3 per min	330Lpm	440Lpm	330Lpm	440Lpm	330Lpm	440Lpm	
Bar	8 Bar	8 Bar	8 Bar	8 Bar	8 Bar	8 Bar	
Bar	400 Bar	520 Bar	400 Bar	520 Bar	400 Bar	520 Bar	
Output Volume*	1.5Kg/min	1.9Kg/min	1.5Kg/min	1.9Kg	1.5Kg/min	1.9Kg/min	
Air Inlet Connection	F 1/4"BSP	F 1/4"BSP	F 1/4"BSP	F 1/4"BSP	F 1/4"BSP	F 1/4"BSP	
Grease Outlet Connection	F 3/8"BSP	F 3/8"BSP	F 3/8"BSP	F 3/8"BSP	F 3/8"BSP	F 3/8"BSP	
Suction Tube	30x480mm	30x480mm	30x740mm	30x740mm	30x940mm	30x940mm	
Shipping Weight/Volume	4.8Kg/0.03m ³	6.1Kg	6.1Kg/0.05m ³	7.4Kg	6.7Kg/0.06m ³	8.2Kg	
Covers and Followers	65310	65310	65400	65400	65600	65600	
Drum Cover Code	66310	66310	66400	66400	66590	66590	

*Footnote: Figures quoted are nominal and vary with grease consistency, distance, air input pressure and volume.

70:1 and 75:1 High Volume, High Pressure Grease Pumps - RAASM 11:1 High Volume, Low Pressure Grease Transfer Pump - RAASM

RAASM's high pressure grease pumps are based on the same 900 and 1200 series air motors as their oil pumps. These high ratio pumps produce higher output pressures and volumes than the 50:1 pumps and are recommended for moving heavy greases and over long distances typically found in large workshops and large centralised systems. RAASM's 900 series 91F/111 is suitable for use as a low pressure/high volume grease transfer pump on service truck and bulk transfer installations.





Brand Series	RAASM 900 / 70:1		RAASM 1200 / 75:1		RAASM 900 / 11:1	
Product Code	91C.701		115F.751		91F.111	
Type	Mono		Flange		Flange	
Applications	Drum/Pod		Drum/Pod		Drum/Pod	
Air Con. cfm/m3 per min	64/1.8		113/3.2		64/1.8	
Max. Input Air Pressure kPa/*MPa/ psi	800/116		800/116		800/116	
Max. Output Pressure* kPa/*MPa/ psi	55.2*/8000		60.0*/8700		1.8*/1200	
Output Volume*	3kg/min		4.4kg/min		5.5kg/min	
Air Inlet Connection	1/2"BSPF		1/2"BSPF		1/2"BSPF	
Grease Outlet Connection	3/8"BSPM		3/8"BSPM		3/4"BSPF	
Suction Tube Diameter	45mm		45mm		45mm	
Shipping Weight/Volume	16kg/0.06m ³		16kg/0.06m ³		16kg/0.06m ³	

Note: 900 and 1200 'F' series pumps include flange and handles, 'C' series is a bare or 'mono-block' pump. 'D' series separated models are also available in stainless steel. *For detailed information on output volume and pressures consult performance curves on the product data sheet for that pump.

Trolleys and Trolley Kits





Drum Trolleys

Drum trolleys take much of the effort and risk of injury out of handling oil and grease drums. Mobilising your oil storage and taking it where the job is can be an economical way of reducing the risk of spills and increasing efficiency without the expense of a fully reticulated dispensing system.

Product Code	Description	Shipping Dimensions	
20/60 Litre 'T' Bar trolley V12200	'T-bar' oil trolley for 60 and 20 Litre drums.	Quantity -1 Weight -1.5kg Size (cm) -100 x 35 x 10	
RAASM 20-60L Drum Trolley 80035	Drum trolley with adjustable base for 20-55kg drums and 20-60 Litre drums.	Quantity -1 Weight -53kg Size (cm) -110 x 65 x 45	
205/180kg Drum Trolley Medium Duty 80200	Medium duty four wheel drum trolley for 205L and 180kg drums, includes swivelling rear castor wheels.	Quantity -1 Weight -22kg Size (cm) -70 x 80 x 85	
205/180kg Drum Trolley Heavy Duty 80201	Heavy Duty four wheel 205L and 180kg 'Super' trolley with full sized rear wheels including brake, tilting tow handle, and hose reel platform.	Quantity -1 Weight -44kg Size (cm) -95 x 85 x 92	

Oil and Grease Dispensing and Recovery trolleys



RAASM oil and grease dispensing trolleys are ideal for maintenance operators and mechanics who need to get oil or grease in drums to equipment or vehicles in a large plant or workshop. The options of built in hose reels and meters on these trolleys make these jobs safer and easier. The oil recovery trolley is ideal for extracting hot oil or diesel fuel from machinery and large vehicle sumps or tanks, facilitating easy disposal direct to the drum.

Product Code	Description	Shipping Dimensions	
Oil Super Trolley 35210 37150	35210 Oil 'Super' Trolley with 3:1 14 lpm air operated pump, 205L bung adaptor, 4 metre delivery hose and end of hose digital meter. 37150 is same as above with 5:1 18 lpm pump for high viscosity oils.	Quantity -1 Weight -56kg Size (cm) -100 x 100 x 18	
Oil Super Trolleys with Hose Reel 37100 35200	37100 Oil 'Super' Trolley with 5:1 18 lpm air operated pump, 205L bung adaptor, 10m x 1/2" hose reel and end of hose digital meter. 35200 is same as above with 3:1 14 lpm pump.	Quantity -1 Weight -73kg Size (cm) -100 x 100 x 24	
Grease Super Trolley 64000	Grease 'Super' Trolley with 50:1 grease pump, drum cover, follower plate, 12m x 1/4" grease hose reel and end of hose control valve with 'z' swivel and flex.	Quantity -1 Weight -86kg Size (cm) -100 x 100 x 24	
Oil Recovery Trolley 45180	Oil recovery trolley kit includes 1:1 oil vacuum pump with gauge, suction probe set and 2m suction/delivery hoses with quick connect. Ideal for recovery into and dispensing from drums.	Quantity -1 Weight -32kg Size -100 x 100 x 12	

RAASM Hose Reels

RAASM series 420

RAASM series 420 open and enclosed spring rewind workshop hose reels are designed for dispensing air, hot and cold water, oil and grease in automotive workshops. Open reels are available in white powder coat finish and stainless steel. The enclosed reels have a white powder coat finish highly suited to modern automotive dealership service centres where neat and unobtrusive appearances are important. Available with fixed and swivelling mountings for single and multiple bank installations. Both model reels carry up to 15 metres of 1/2" oil hose, 18 metres of 3/8" air hose or 18 metres of 1/4" grease hose, 0.6 metre inlet hose.

Product Code	Working Pressure Bar	Hose Dimensions	Inlet Connection	Outlet Connection	Nominal Shipping		
Series 420 Open							
Open Air							
8420.100 swivel	20 Bar	Bare Reel	1/2" BSPF	1/2" BSPF	Weight 28kg Volume 0.04m3		
8420.101 swivel	20 Bar	12m x 1/8"	1/2" BSPF	1/2" BSPM			
8420.104 swivel	20 Bar	15m x 1/2"	1/2" BSPF	1/2" BSPM			
Open Water							
8420.300 swivel	200Bar	Bare Reel	1/4" BSPF	1/2" BSPF			
8420.302 swivel	200Bar	12m x 3/8"	3/8" BSPF	3/8" BSPF			
8420.104 swivel	200Bar	15m x 1/2"	1/2" BSPF	1/2" BSPM			
Open Oil							
8420.400 swivel	150 Bar	Bare Reel	1/2" BSPF	1/2" BSPF			
8420.402 swivel	150 Bar	15m x 1/2"	1/2" BSPF	1/2" BSPM			
8420.401 swivel	150 Bar	10m x 1/2"	1/2" BSPF	1/2" BSPM			
8430.401 fixed	150 Bar	10m x 1/2"	1/2" BSPF	1/2" BSPM			
Open Grease							
8420.500 swivel	600 Bar	Bare Reel	1/4" BSPF	1/2" BSPM			
8420.501 swivel	600 Bar	12m x 1/4"	1/4" BSPF	1/4" BSPM			
8430.506 fixed	600 Bar	15m x 3/8"	1/2" BSPF	1/2" BSPM			
Enclosed Air/Water							
8440.100 swivel	20 Bar	Bare Reel	1/2" BSPF	1/2" BSPF	Weight 25kg Volume 0.03m3		
8440.101 swivel	20 Bar	12m x 3/8"	1/2" BSPF	1/2" BSPM			
8440.104 swivel	20 Bar	15m x 1/2"	1/2" BSPF	1/2" BSPM			
Enclosed Oil							
8440.400 swivel	150 Bar	Bare Reel	1/2" BSPF	1/2" BSPF			
8440.402 swivel	150 Bar	15m x 1/2"	1/2" BSPF	1/2" BSPM			
8440.401 swivel	150 Bar	10mm x 1/2"	1/2" BSPF	1/2" BSPM			
Enclosed Grease							
8440.500 swivel	600 Bar	Bare Reel	1/4" BSPF	1/2" BSPM			
8440.501 swivel	600 Bar	12m x 1/4"	1/4" BSPF	1/4" BSPM			
8440.506 swivel	600 Bar	15m x 3/8"	1/4" BSPM	3/8" BSPM			

RAASM Series 510 Open, Long Hose Reels

RAASM series 510 open spring rewind hose reels are similar in design to the series 420 reels but feature larger diameter drums and larger springs to carry up to 25 metres of 1/2" hose. Available with fixed or swivelling mountings in white powder coat finish or stainless steel for air, hot and cold water, and oil.

Air							
8520.100	20 Bar	25m x 1/2"	1/2" BSPF	1/2" BSPF	Weight 19kg Volume 0.07m3		
Water							
8520.100	20 Bar	25m x 3/8"	3/8" BSPF	3/8" BSPF			
Oil							
8520.402	150 Bar	25m x 1/2"	1/2" BSPF	1/2" BSPF			

RAASM Series 260 Demountable Air/Water Reel

RAASM's series 260 enclosed hose reel is an ideal medium duty compact air and water reel for workshop and forecourt installations. Complete with demountable bayonet coupling the complete reel can be quickly removed for secure storage. Includes 11 metre x 8mm nominal bore hose with 1/4" BSPM inlet and 1/4" BSPM swivel coupling at outboard end. Max working pressure 20 bar. Relative capacity 280 LPM.

Series 260 Air/Water Reel							
89010*	20 Bar	11m x 8mm	1/4" BSPM	1/4" BSPM	Weight 7kg		
Volume 0.01m3							
Bayonet Coupling 89001							
Note: *Asterisk denotes swivelling mount, all other hose reels are fixed mounting.							

Continued...

Air/Water	Working Pressure Bar	Hose Dimension	Inlet Connection	Outlet Connection	Nominal Shipping	
8540.100	20 Bar	Bare	1" BSPF	1" BSPF	Weight - 24Kg Volume - 0.12m ³	
8540.102	20 Bar	20" x 3/4"	1" BSPF	1" BSPF	Weight - 24Kg Volume - 0.12m ³	
Oil						
8540.400	150 Bar	Bare	1" BSPF	1" BSPF	Weight - 24Kg Volume - 0.12m ³	
8540.401	150 Bar	15m x 3/4"	1" BSPF	3/4" BSPF	Weight - 40Kg Volume - 0.12m ³	
8540.402	150 Bar	20m x 3/4"	1" BSPF	3/4" BSPF	Weight - 40Kg Volume - 0.12m ³	
8540.403	150 Bar	15m x 1"	1" BSPF	1" BSPF	Weight - 40Kg Volume - 0.12m ³	

RAASM Stainless Steel Reels (open)









	Working Pressure Bar	Hose Dimension	Inlet Connection	Outlet Connection	Nominal Shipping	
Series 420 8424.350	400 Bar	Bare	3/8" BSPF	1/2" BSPF	Weight - 20Kg Volume - 0.065m ³	
8422.352	400 Bar	18m x 3/8"	3/8" BSPF	3/8" BSPm	Weight - 25Kg Volume - 0.065m ³	
Series 520 8524.350	400 Bar	Bare	3/8" BSPF	3/8" BSPm	Weight - 25Kg Volume - 0.065m ³	
Series 540 8544.200	100 Bar	Bare	1" BSPF	1/2" BSPF	Weight - 24Kg Volume - 0.12m ³	

Hose Reel Drip Trays

Product Code	Description	Shipping Dimensions	
Drip Tray 88630	RAASM hose reel drip tray includes gun hook for keeping hose and gun in place and removable drip tray for easy cleaning. An indispensable hose reel accessory that keeps your workshop safe and clean.	Quantity 1 Weight 5.3kg Size 90 x 20 x 17	

Oil, Grease Meters and Control Valves

Oil and Grease Meters and Control Valves

Product Code	Description	Shipping Dimensions	
RAASM End of Hose Ball Cock 33123	End of hose control valve equipped with 3/4" BSPF ball cock and spout. Simple end of hose valve for high volume transfer of most fluids.	Quantity -1 Weight -0.35kg Size (cm) -30 x 4 x 15	
RAASM Oil Gun 38025	End of hose control valve for engine and gear oil includes flexible extension and high flow non drip tip. 1/2" BSPF straight swivel connection.	Quantity -1 Weight -0.75kg Size (cm) -40 x 4 x 10	
RAASM Transfer Gun 33120	End of hose transfer gun with high flow open ended rigid spout. Ideal as an end of hose control valve for water, coolant, waste oil or for high flow oil transfer. 1/2" BSPF straight swivel connection.	Quantity -1 Weight -0.75kg Size (cm) -40 x 4 x 10	
RAASM High Flow Nozzle 33122	High flow low pressure bowser style end of hose nozzle for high volume oil and coolant transfer. Equipped with 3/4" BSPF straight swivel connection.	Quantity -1 Weight -0.75kg Size (cm) -40 x 4 x 10	
End of Hose Control Valve Engine Oil 38021 Gear Oil 38022	Durable cast alloy control valves for engine and gear oils including High flow non drip tip. 38022 comes with flexible extension. Ideal for use with 37711 in line digital in line batch meter. 38021 with rigid spout.	Quantity -1 Weight -1kg Size (cm) -28 x 8 x 9	
Digital In Line Batch Meter for Oil 37711	Oval gear digital batch meter for in line measurement of oil and coolant flow suited for viscosities to SAE 250. 1/2" BSPF inlet and outlet.	Quantity -1 Weight -1.5kg Size (cm) -40 x 13 x 13	
Digital End of Hose Oil Meter 37714	Oil gun equipped with digital line-counter. 1/2"F inlet swivel joint. Flexible hose and non-drip tip.	Quantity -1 Weight -2kg Size (cm) -28 x 16 x 16	
Pre-set digital end of hose meter TECB500	Digital preset end of hose meter, which dispenses preset volumes from 0.1 to 99.9 litres.	Quantity -1 Weight -3kg Size (cm) -30 x 16 x 16	
High delivery Oil Guns 33151	High delivery oil gun with 3/8" swivel inlet, lever locking button & flexible hose with non-drip tip.	Quantity -1 Weight -4kg Size (cm) -60 x 5 x 16	

IBC Solutions

Product Code - 36610

Kit for dispensing from tank. A complete solution for dispensing oil and allied products. The dispensing pump and the hose reel are fixed directly to the tank by means of sturdy brackets.

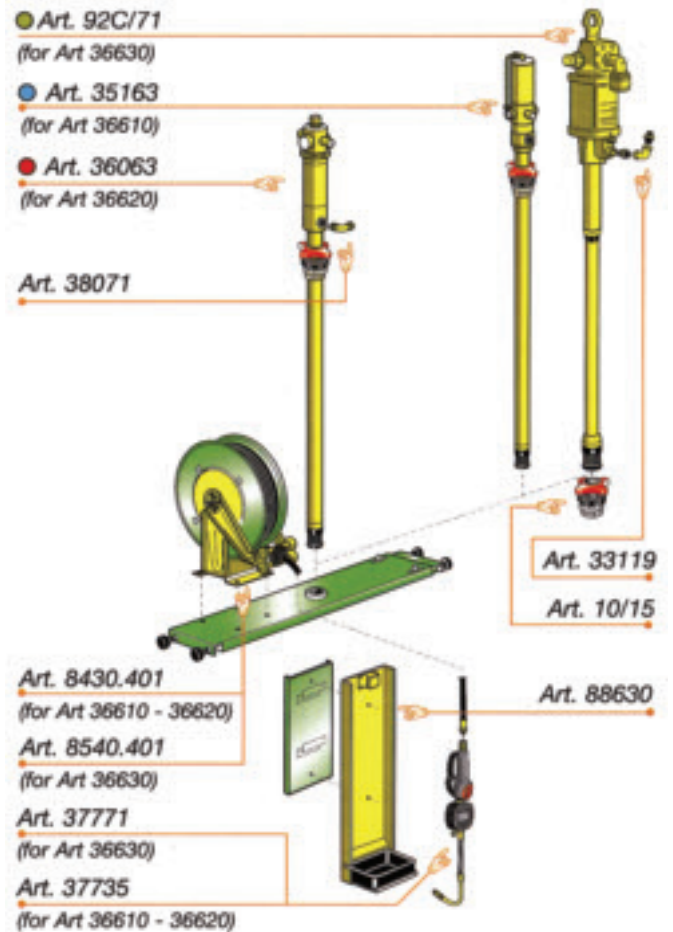

Product Code - 36610

Dispensing kit for oil and allied products with pump inserted centrally and enclosed hose reel, complete with:

- 35163 pump R 3:1 - 14 L/min
- 36601 support bracket
- 8430.401 hose reel with 10m hose Ø 1/2"
- 37735 metering gun
- 38071 nipple 1/2" x 1/2" G M/M
- 88630 drip tray

IBC Solutions

Product Code - 36670

System for dispensing from tank with pump applied to the drain.
 A complete solution for dispensing oil and allied products.
 The dispensing pump and hose reel are fixed directly to the tank by means of sturdy brackets.
 The pump connection is fixed to the tank drain.

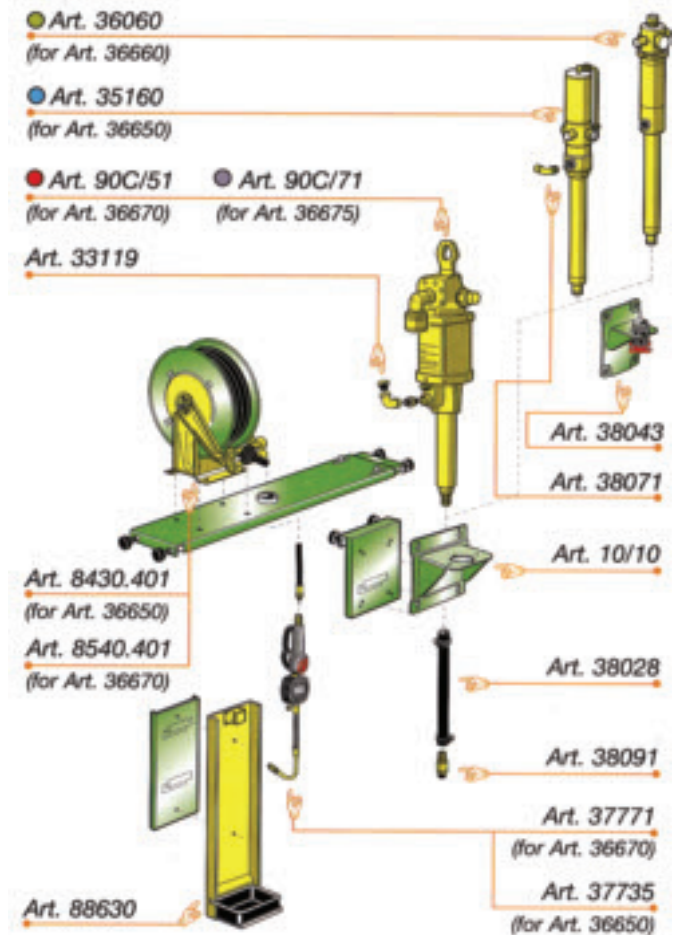

Product code - 36670

Dispensing kit for oil and allied products with pump connected to the tank drain and hose reel, complete with:

- 90C/51 pump R 5:1 - 45 L/min
- 10/10 pump support bracket
- 8540.401 hose reel with 15m hose Ø 3/4"
- 38028 flexible suction hose
- 38091 check valve
- 37771 metering gun 1/2"
- 36641 support bracket
- 88630 drip tray
- 33119 nipple 1" x 3/4" G - MM

quantity. 4 packing m³ 0,280 kg 72

OilPro Oil Management System



The OilPro Oil Management System is used mainly in vehicle and truck workshops to manage fluid dispensing from bulk tank to dispensing bay. (Other applications are available)

The Product delivers specified quantities of oil / fluid from bulk tanks to dispensing points, while keeping accurate records of all transactions. It is an effective loss control system, providing protection against unauthorized dispensing.

OilPro V4 Oil Management System

A leader in its field. The system combines the latest and most relevant technologies in Electronics and Information Technology, thereby addressing the dynamic challenges of the Information Age.

Email notifications of bulk product level status when low. Daily usage report can be emailed to relevant people.

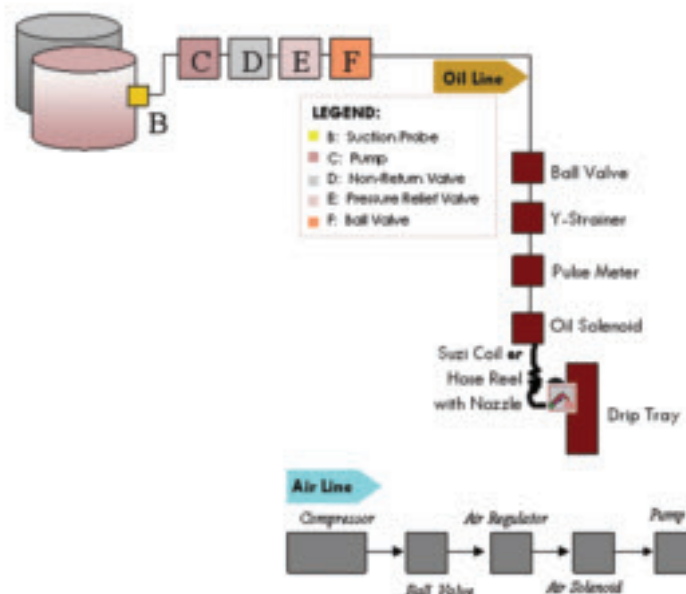





Installation Accessories



High Pressure Grease Swivels

Straight Swivel 66661	RAASM Straight swivel 1/4" x 1/4" BSPF/M	Quantity -1 Weight -0.1kg Size (cm) -3 x 2 x 2	
'Z' Swivels 66663	RAASM 'Z' swivel 1/4" x 1/4" BSPF/M	Quantity -1 Weight -0.1kg Size (cm) -6 x 3 x 3	

Grease Control Valves

Grease Control Valve with Flex Extension 66860	RAASM end of hose grease gun with flexible extension. 1/4" BSPF inlet.	Quantity -1 Weight -0.8kg Size (cm) -23 x 4 x 12	
Grease Control Valve Rigid Extension 66880	RAASM end of hose grease gun with rigid extension. 1/4" BSPF inlet.	Quantity -1 Weight -0.6kg Size -12 x 4 x 12	
Grease Control Valve including Flex and Swivel 66889	RAASM end of hose grease gun with flexible extension and 'z' swivel. 1/4" BSPF inlet	Quantity -1 Weight -0.9kg Size (cm) -23 x 4 x 16	
Grease Control Valve Heavy Duty BK7000	Tecalemit high pressure heavy duty end of hose grease control valve, features solid cast brass body with precision fit piston and easy grip trigger. 1/8" NPTF.	Quantity -1 Weight -1.0kg Size (cm) -30 x 5 x 15	
Digital EOH Grease Meter 66899	Digital end of hose grease meter for use with air operated pumps. Ideal for applications where over greasing is a problem or precision dispensing is required. Features variable delivery rate for low and medium volume dispensing up to 1.5kg/min. Volume display resolution to 1gram, precision +/- 3%. Operating pressure to 8000psi. Inlet 1/4" BSPF, outlet 1/8" BSPF fitted with rigid extension and hydraulic nipple connector.	Quantity -1 Weight -2kg Size (cm) -24 x 15 x 15	





Air and Water Control Valves

Tyre Inflator V14391	Tyre inflator 0-150psi including dual chuck and gauge.	Quantity -1 Weight -2kg Size (cm) -35 x 12 x 7	
Water Faucet V14220	End of hose water faucet.	Quantity -1 Weight -0.9kg Size (cm) -33 x 10 x 4	
Transfer Gun 33120	RAASM water and coolant transfer gun with high flow open ended rigid spout. 1/2" BSPF straight swivel connection.	Quantity -1 Weight -0.75kg Size (cm) -40 x 4 x 10	



Installation Accessories

Product Code	Description	Shipping Dimensions	
Air Filter Regulator Lubricator TECFRL	1/2" Air filter regulator lubricator and pressure gauge with adjustable oil lubricator for use with air operated pumps.	Quantity - 1 Weight - 0.9kg Size (cm) - 16 x 8 x 12	

Wall and Drum Mounting Accessories for RAASM Oil Pumps

Steel Wall Bracket 38043	Heavy duty wall bracket for mounting RAASM oil pumps in 2"BSP bung adaptor.	Quantity - 1 Weight - 1kg Size (cm) - 12 x 14 x 14	
33115	Wall mounting bracket for 33060/33160.	Quantity - 1 Weight - 1kg Size (cm) - 12 x 14 x 14	
205L Drum Bung Adaptor 38042	2"BSPM drum bung adaptor for mounting RAASM oil pumps in drums.	Quantity - 1 Weight - 0.3kg Size (cm) - 12 x 10 x 10	
Suction Spear 38027 38055	Remote suction spear for wall mounting RAASM pumps. 205L drum & IBC applications	Quantity - 1 Weight - 1kg Size (cm) - 10 x 10 x 50	
Suction Hose 38026	Rassm Pumps Suction hose for wall mounted pumps.	Quantity - 1 Weight - 1kg Size (cm) - 30 x 30 x 10	
Connection Hose 91202	2m x 1/2" pump – wall/reel oil connection hose.	Quantity - 1 Weight - 1.5kg Size (cm) - 30 x 30 x 20	

Wall and Drum Mounting Accessories for RAASM Series 900 and Series 1200 Pumps

Wall bracket 10.10	Wall bracket for series 900 and 1200 mono-block and flange pumps.	Quantity - 1 Weight - 0.5kg Size (cm) - 20 x 20 x 15	
Wall bracket 10.11	Wall bracket with shock absorbers for Series 900 and 1200 mono-block and flange pumps.	Quantity - 1 Weight - 0.5kg Size (cm) - 20 x 20 x 15	
Wall bracket 10.12	Wall bracket for Series 900 and 1200 separated pumps.	Quantity - 1 Weight - 0.5kg Size (cm) - 20 x 20 x 15	
Wall bracket 10.13	Wall bracket with shock absorbers for Series 900 and 1200 separated pumps.	Quantity - 1 Weight - 0.5kg Size (cm) - 20 x 20 x 15	
Bung Adaptor 10.14 10.15	Bung adaptor for 45mm diameter pump spears. Bung adaptor for 53mm diameter pump spears.	Quantity - 1 Weight - 0.02kg Size (cm) - 8 x 8 x 8	
Handles 10.16	Handles for flange and separated pumps.	Quantity - 1 Weight - 0.01kg Size (cm) - 15 x 10 x 5	
Foot Valve 10.20	Suction spear foot valve and strainer 1" BSPF.	Quantity - 1 Weight - 0.02kg Size (cm) - 8 x 8 x 8	

Continued...

Oil Bars



Oil bars are a safe and convenient way to access oil from bulk tanks or drums. Air operated pumps make dispensing easy and facilitate the use of purpose designed remote oil storage areas away from the work area without committing to a fully reticulated hose reel system. Available in one to three tap configurations with or without meters, and in drum top kits.

Product Code	Description	Shipping Dimensions	
Oil Bars 37690 37691	Single tap oil bar with integrated anti splash filter. Single tap oil bar with digital meter. Expandable to two or three taps with meters. Drip tray can be removed for cleaning. Also suitable for coolant.	Quantity - 1 Weight - 24kg Size (cm) - 60 x 32 x 56	
Hose Kit 37693	Oil bar connecting hose kit includes 60cm x 1/2" BSPF hose, elbow and M/F nipple.	Quantity - 1 Weight - 3kg Size (cm) - 20 x 20 x 10	
Oil Bar Tap 37692	Double valve oil bar tap. Anti-splash filter eliminates sprays and spurts if air is entrained in the system. This item is not sold separately.	Quantity - 1 Weight - 1kg Size (cm) - 20 x 20 x 10	
Oil Bar Meter 37694	Digital meter kit including connection fittings.	Quantity - 1 Weight - 2kg Size (cm) - 40 x 40 x 20	

Oil Bar for Drums







Oil Bar for Drums 37697	Oil bar pump for 205L drums, includes 3:1 14lpm oil pump, fixed steel spout pipe, oil bar tap and drip tray. The easy way to get oil from drums.	Quantity - 1 Weight - 12kg Size (cm) - 10 x 10 x 35	
-----------------------------------	--	---	---

Parts Washers



RAASM Universal washing tank 70365	Mobile reservoir mounted parts washer with 50 Litre washing tank is ideal for workshop applications including washing disk brake assemblies on car. Includes wash brush on hose and air gun. Dual mode operation either continuous flow through brush or as an air agitated soaker/dip tank. Low pressure pneumatic flow system is low maintenance and intrinsically safe.	Quantity - 1 Weight - 47kg Size (cm) - 50 x 66 x 106	
Parts washer 240ltr with flow through brush – free standing TEC65000	240 Litre heavy duty parts washing tank with highquality oil filled electric pump and flow through wash brush. Free standing sheet metal construction with storage shelf and overhead light. Complies with AS3100-1990.	Quantity - 1 Weight - 53kg Size (cm) - 110 x 65 x 45	

Grease, Oil Guns and Accessories

Grease and Oil Guns

Product Code	Description	Shipping Dimensions	
Grease Gun 400g Lever Style TEC400 400g Pistol Style TEC400M	Economical lever style grease gun for European and US style 400g cartridges or bulk filling. Economical pistol grip grease gun for 400g cartridges or bulk filling.	Quantity -1 Weight -2kg Size- 44 x 15 x 10	
Grease Gun, 450g Lever Style Cartridge and Bulk TEC450	Heavy Duty lever style high pressure grease gun with forged brass head and precision ground piston to eliminate seals. Generates 7500psi. Supplied with rigid extension and 4 jaw hydraulic connector.	Quantity -1 Weight -2kg Size -44 x 12 x 7	
Grease Gun, 450g Pistol Style Cartridge and Bulk TEC450M	Heavy Duty Pistol style medium pressure grease gun with lightweight cast alloy head and precision ground piston. Ergonomic trigger style handle is designed for one handed operation. Generates 5000psi. Supplied with flexible extension and 4 jaw hydraulic connector.	Quantity -1 Weight -2.5kg Size- 44 x 18 x 7	
Grease Gun, 450g Air Operated Cartridge and Bulk TECAIR450	Heavy duty air operated pistol style grease gun. 50:1 ratio develops 5000psi output. Supplied with rigid extension and 4 jaw hydraulic connector.	Quantity -1 Weight -2kg Size -43 x 23 x 13	
PomPom Style Grease and Oil Gun 142 Gram Capacity GB2800	Push style 'PomPom' gun for grease and oil 142 gram capacity bulk fill cylinder	Quantity -1 Weight -0.6kg Size- 60 x 60 x 14	
Oil Suction Guns 160ml 850.247 570ml 850.248	Oil suction guns are ideal for sucking hot and cold oil from a variety of sumps, gearboxes and reservoirs on a variety of equipment.	Quantity -1 Weight -1kg Size -40 x 10 x 10	

Hand operated grease pumps

Product Code	Description	Shipping Dimensions	
Hand Operated High Pressure Grease Pump for 20kg pails 60310	20kg manual grease pump kit includes pump, drum cover, follower, 2.5 metre delivery hose and rigid extension with ball cock and hydraulic connector. Delivers approximately 6 grams per stroke at 2000psi/14MPa.	Quantity -1 Weight -7kg Size (cm) -40 x 40 x 65	
Hand Operated High Volume Transfer Pump for 20kg pails 60410 Quick Connect Female 60450 Male 60451	Hand operated high volume transfer pump includes pump, drum cover, follower, 2 metre delivery hose and rigid hi-flow extension with ball cock. Optional quick connect couplings available for refilling fixed plant reservoirs such as truck chassis lube units. Delivers approximately 50 grams per stroke at 265psi/1800kPa. Male and female quick connect fittings available for end of hose.	Quantity -1 Weight -6kg Size (cm) -40 x 90 x 80	

Grease Gun Connectors

Grease Gun Connectors, extensions and flexes

4 Jaw Hydraulic Connector for Standard Nipples HF4048 66740	4 jaw hydraulic connector with steel seat for high pressure connections. Gold passivated for corrosion protection and easy identification. RAASM 4 jaw grease chuck.	Quantity -1 Weight -0.05kg Size (cm) -3 x 2 x 2	
Needle Point Connector HF4100	Needle point connector with narrow connector head pushes grease nipple balls down allowing free passage of grease into the nipple without high pressure. Ideal for hard to get at nipples as found on CV joints.	Quantity -1 Weight -0.05kg Size (cm) -3 x 2 x 2	
TAT Hook on Connector HF4016	1/8" BSP hook on connector for button head nipples.	Quantity -1 Weight -0.05kg Size (cm) -3 x 2 x 2	
Giant Button Head Hook on Connector HF4020	1/8" BSP hook on connector for giant button head grease nipples.	Quantity -1 Weight -0.05kg Size (cm) -3 x 2 x 2	
TAT style thrust on Connector HF4063	TAT thrust on connector pushes on to button head nipples.	Quantity -1 Weight -0.05kg Size (cm) -3 x 2 x 2	
Concave Connector HF4034	Concave connector suits concave shaped oil nipples and cups.	Quantity -1 Weight -0.05kg Size (cm) -3 x 2 x 2	
Zerk Connector 6410	Convex connector suits convex shaped oil nipples.	Quantity -1 Weight -0.05kg Size (cm) -3 x 2 x 2	
Straight swivel HE3913	1/8" BSP (M/F) swivel for fitting to grease gun flexes enable connectors to be rotated.	Quantity -1 Weight -0.05kg Size (cm) -3 x 2 x 2	
High pressure flex 18" PNH3009.18 10" PNH3009.10	High pressure flex allows greasing of nipples in hard to reach places not accessible with rigid connectors. Ideally suited to pistol style grease guns set up for one handed operation. 1/8" BSPM both ends	Quantity -1 Weight -0.05kg Size (cm) -26 x 2 x 2	
Grease Gun Flex and Connector Assembly V14481	PNH3009.10-10" flex with HF4048 4 jaw hydraulic connector.	Quantity -0 Weight -0.05kg Size (cm) -26 x 2 x 2	

Single Point Grease Lubricators

Mechanical single point grease lubricators 78g GS.125 150g GS.135	Mechanical single point lubricators with refillable reservoir. Spring operated design with adjustable flow rate is simple and reliable for bearing applications which require steady continuous grease flow. Clear reservoir and filler nipple make monitoring and refilling easy.	Quantity -1 Weight 0.2kg Volume 15x7x7	
--	--	--	---

Grease Nipples and Assortments

Assortments

<p>Product Code V4679</p> <p>Product name Automotive grease nipple assortment</p> <p>Contains: 10 x H29 1/8" BSP straight, 5 x HA34 1/8" BSP 450, 5 x HA39 1/8" BSP 67 1/20, 5 x HA44 1/8" BSP 900, 20 x H3 1/4" SAE Taper Straight, 10 x HA7 1-4" SAE Taper 450, 5 x H127 1/4" 28SAE Taper Long Straight, 5 x HA107 1/4" 28UNF 900, 20 x H161 6 x 1mm Straight, 10 x HA168 6 x 1mm 450, 10 x HA165 6 x 1mm 900, 1 x HF4048 Hydraulic nipple connector.</p>	
<p>Product Code V4675</p> <p>Product name Industrial grease nipple assortment</p> <p>Contains: 9 x H1 1/4" BSF straight, 6 x HA8 1/4" BSF 67 1/20, 6 x H12 5/16" BSF straight, 6 x HA20 5/16" BSF 67 1/20, 9 x H3 1/4" 28SAE Straight, 6 x H127 1/4" 28SAE Long straight, 6 x HA7 1/4" 28SAE 450, 3 x HA107 1/4" 28UNF 900, 12 x H28 1/8" ANP Straight, 6 x HA37 1/8" ANP 67 1/20, 6 x HA43 1/8" ANP 900, 18 x H29 1/8" BSP Straight, 6 x HA39 1/8" BSP 67 1/20, 6 x HA44 1/8" BSP 900, 3 x H48 1/4" BSP Straight.</p>	
<p>Product Code V4676</p> <p>Product name Metric grease nipple assortment</p> <p>Contains: 6 x H15 8 x 1.25mm Straight, 6 x HA173 8 x 1.25mm 900, 6 x HA176 8 x 1.25mm 450, 6 x H158 8 x 1mm Self tapping, 6 x H162 8 x 1mm Straight, 6 x HA169 8 x 1mm 900, 6 x HA172 8 x 1mm 450, 6 x HA205 10 x 1mm 450, 6 x H161 6 x 1mm straight, 6 x HA165 6 x 1mm 900, 6 x HA168 6 x 1mm 450, 6 x H163, 6 x 1mm Self tapping, 6 x H204 10 x 1mm Straight, 6 x H206 10 x 1mm 900.</p>	

Grease Nipples Straight

Product Code	Description	Pack Qty	Shipping Weight per box
H1	1/4" x 26 BSF Straight	100	1
H113	1/4" x 26 BSF Long Straight	100	2
H29BP	1/8" BSP Straight	20	0.4
H29	1/8" BSP Straight	100	2
H48	1/4" BSP Straight	100	2
H28	1/8" ANP Straight	100	2
H47	1/4" NPT Straight	100	2
H2	1/4" x 20 Whitworth Straight	100	1
H185	1/4" 28 UNF Straight	100	1
H123	1/4" 28 UNF Straight	100	2
H3BP	1/4" 28 SAE Taper Straight	20	0.4
H3	1/4" 28 SAE Taper Straight	100	1
H114	1/4" 28 SAE Taper L.T. Straight	100	2
H195	3/8" x 24 UNF	100	2
H127	1/8" x 28 SAE Taper Long Straight	100	2
H161BP	6 x 1mm Straight	20	0.4
H161	6 x 1mm Straight	100	1
H162	8 x 1mm Straight	100	1
H204	10 x 1mm Straight	100	2
H15	8 x 1.25mm Straight	100	2
H147	3/16" Self Tapping Straight	100	2
H163	6mm Self Tapping Straight	100	1
H158	8 x 1mm Self Tapping Straight	100	1
H77	1/4" Drive fit Straight – no check valve	100	1
H78	1/4" Drive fit Straight – with check valve	100	1
H79	5/16" Drive fit Straight – with check valve	100	1
H80	5/16" Drive fit Straight – no check valve	100	2



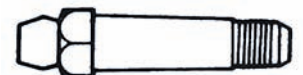

straight



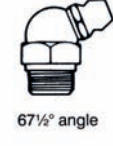
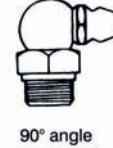

Continued...

Grease Nipples Angled



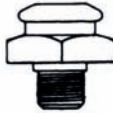
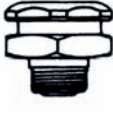





Product Code	Description	Pack Qty per box	Shipping Weight	
H5	1/4" x 26 BSF 350 Angle	100	2	
HA34	1/4" 20 BSF 350 Angle	100	2	
H52	1/8" BSF 350 Angle	100	2	
HA7	3/8" 28 SAE Taper L.T. 450 Angle	100	2	
HA138	1/4" ANP 450 Angle	100	2	
HA168BP	6 x 1mm 450 Angle	20	0.4	
HA168	6 x 1mm 450 Angle	100	2	
HA172	8 x 1mm 450 Angle	100	2	
HA176	8 x 1.25mm 450 Angle	100	2	
HA205	10 x 1mm 450 Angle	100	2	
HA8	1/4" 26 BSF 67 1/20 Angle	100	2	
HA20	5/16" 22 BSF 67 1/20 Angle	100	2	
HA39	1/8" BSP 67 1/20 Angle	100	2	
HA56	1/4" BSP 67 1/20 Angle	100	2	
HA9	1/4" 20 Whit 67 1/20 Angle	100	2	
HA37	1/8" NPT 67 1/20 Angle	100	2	
HA188	1/4" 28 UNF 67 1/20 Angle	100	2	
HA10	1/4" 26 BSF 900 Angle	100	2	
HA43	1/8" ANP 900 Angle	100	2	
HA44BP	1/8" BSP 900 Angle	20	0.4	
HA44	1/8" BSP 900 Angle	100	2	
HA60	1/4" BSP 900 Angle	100	2	
HA107	1/4" 28 UNF 900 Angle	100	2	
HA134	1/4" 28 SAE Taper L.T. 900 Angle	100	2	
HA165BP	6 x 1mm 900 Angle	20	0.4	
HA165	6 x 1mm 900 Angle	100	2	
HA169	8 x 1mm 900 Angle	100	2	
HA173	8 x 1.25mm 900 Angle	100	2	
HA206	10 x 1mm 900 Angle	100	2	
HA210	10 x 1.5mm 900 Angle	100	2	

Industrial Nipples

4785.13	1/4" BSP Straight button	100	3	
4788.1	1/8" BSP Straight button	100	3	
Industrial TAT Nipples	1/8" BSP Straight TAT	100	2	
T46	1/4" BSP Straight TAT	100	2	
T52	1/4" BSP Straight brass	100	2	
T52PB	TAT with phosphor ball and spring	100	2	
Extensions				
4668D	1/8" BSPM/F 1/2" long	10	2	
4668E	1/8" BSPM/F 1" long	10	4	
4668J	1/8" BSPM/F 1 1/2" long	10	6	
4668K	1/8" BSPM/F 2" long	10	8	

Diesel Fuel Handling Equipment

Pumps and Accessories



Product Code	Description	Shipping Dimensions	
High capacity rotary pump for 60 and 205 Litre drums TEC50032 Koshin high capacity rotary pump for 60 and 205 Litre drums LP32	High volume rotary drum pumps suited to transfer of diesel, oil and coolant at approximately one Litre per revolution. Adjustable height bung adaptor suits 60 and 205 Litre drums. Fuel transfer accessories including heavy duty bung adaptor, hose kit and fuel filter available. Both pumps feature durable alloy construction and oil filled gearbox.	Quantity -1 Weight -7kg Size (cm) -100 x 30 x 15	
TEC50032H	High volume rotary drum pumps suited to transfer of diesel, oil and coolant at approximately one Litre per revolution. Adjustable height bung adaptor suits 60 and 205 Litre drums. Fuel transfer accessories including heavy duty bung adaptor, hose kit and fuel filter available. Both pumps feature durable alloy construction and oil filled gearbox. With hose and nozzle holster.	Quantity - 1 Weight - 8Kg Size (cm) - 53 x 36 x 20	
Diesel Fuel Hose and Filter Kit TECFK1	Diesel Fuel hose and filter kit to suit high volume rotary pumps. Includes 90 degree elbow, filter, hose, spout, holster and drum bung weather seal to prevent water entering drums.	Quantity -1 Weight -4kg Size (cm)- 45 x 22 x 22	
Diesel Fuel Filter/Water Separator 496BSP Filter Elements 496.5	1" BSP ported diesel fuel filter and water separator with replaceable filter cartridge. Suits TECFK1 fuel transfer hose kit. Filter cartridge.	Quantity -1 Weight -0.06kg Size (cm) -16 x 11 x 11 Quantity -1 Weight -0.03kg Size (cm) -10 x 8 x 8	
Heavy Duty Steel 205L Drum Bung Adaptor V20484	Galvanised solid steel 2" BSP drum bung adaptor for fitting heavy pumps to 60 and 205 Litre drums.	Quantity- 1 Weight -2kg Size (cm) -10 x 10 x 4	
Battery Powered Diesel Drum Pumps TECVF 40-12V 40 Lpm	12 volt battery powered diesel fuel drum pump delivers 40 Litres/min. Kit includes 205 Litre telescopic suction spear mounted pump, 3 metre delivery hose and nozzle.	Quantity -1 Weight -7kg Size (cm) -30 x 30 x 26	
TECVF80-12V 80 Lpm	12 volt battery powered diesel fuel drum pump delivers 80 Litres/min. Kit includes 205 Litre telescopic suction spear mounted pump, 3 metre delivery hose and nozzle.	Quantity -1 Weight -14kg Size (cm) -60 x 30 x 33	
TECBATKIT 40 Lpm	12 volt battery powered diesel fuel transfer pump delivers 40 Litres/min. Kit includes flexible suction hose with inlet filter, pump mounted on base plate, 4 metre delivery hose and hand piece. Portability and flexible suction hose make this kit ideal for transferring fuel from tank to tank.	Quantity -1 Weight -10kg Size (cm) -48 x 48 x 20	

Continued...

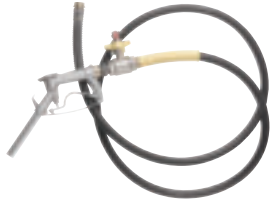

Gravity Tank Hose Kits

Product Code	Description	Shipping Dimensions	
Gravity Tank Hose Kit TECGRAVHOSE	Gravity tank hose kit includes 3 metre delivery hose with lockable ball valve, and nozzle with swivel.	Quantity -1 Weight -5kg Volume -43 x 43 x 12	
Lockable Ball Valve TECLBV	Lockable 1" BSP outlet valve with three position lock allows access to fuel storage tanks via master key, with trustee key or without key, and can be locked without a key. Ideal for securing remote storage tanks on farms, trailers and mobile equipment to which staff, contractors or family require periodic access. Valve is fitted between tank and hose.	Quantity -1 Weight -1kg Volume -10 x 8 x 8	

Meters

Mechanical Flow Meter 3 Digit Face TECUR300 4 Digit Face TECUR400	Mechanical flow meter with 1" BSP inlet and outlet. Flow rate 20-80LPM. Max working pressure 3 bar. UR300 has reset-able 3 digit dial face displays up to 999.9 Litres, UR400 has 4 digit dial face displaying up to 9999.9 Litres – both with 6 digit totaliser. Face rotates 90 degrees for vertical or horizontal mounting. Corrosion resistant housing and hardy cast alloy construction make this an ideal farm gravity tank and 12 volt pump meter for tracking diesel usage. Not for fuel resale use.	Quantity -1 Weight -2kg Volume- 20 x 16 x 18	 
--	--	--	---

Fuel Dispensing Nozzles

Aluminium Nozzle and Swivel TECUR6000	Aluminium Nozzle and 1" BSP swivel suitable for Diesel Fuel.	Quantity -1 Weight -0.7kg Volume -40 x 5 x 16	 
Auto Shut Off Nozzles TECAUTOSHUTOFF	50LPM auto shut off nozzle including 3/4" BSP swivel suitable for use with 40LPM 12V transfer pumps.	Quantity -1 Weight -2kg Volume -40 x 7 x 18	
TECTL80	80LPM 1" BSP auto shut off nozzle suitable for use with 80LPM 12V transfer pumps and non-resale* bowzers.	Quantity -1 Weight- 2kg Volume -40 x 7 x 18	
High Flow Nozzle TECTL120	120LPM 1" BSP high flow auto shut off nozzle for non-resale* fuel bowzers and high flow pumps.	Quantity -1 Weight- 2kg Volume -40 x 7 x 18	
1" BSP Swivel TECTL120S	1" BSP swivel for TECTL80 and TECTL120 *NOTE: AS1940 prohibits the use of auto-shutoff nozzles in resale and marine refuelling installations.	Quantity -0 Weight -0.05kg Volume -2x 2 x 2	

Hand Pumps

Lever and stroke pumps

Product Code	Description	Shipping Dimensions	
Drum Pumps Engine Oil 20 Litre TEC50420 60 Litre TEC50460 ATF 20 Litre TEC51420 60 Litre TEC51460	Drum pumps for handling engine oil, gear oil, ATF and hydraulic fluids. ATF pumps include a removable washable strainer built into the handle to help prevent contaminants reaching critical valves. Pumps come complete with 1.2 metre delivery hose, bung holster and non drip tips. Oil delivery is approximately 200 ml on the down stroke.	Quantity - 1 Weight - 2kg Size (cm) - 50 x 25 x 10	
20 Litre Spring Prime Pumps Engine Oil TEC50520 ATF TEC51520	Spring prime pumps allow oil to be pressurised and released via end of hose control valve. Ideal for servicing diffs or transmissions with hard to reach fill points.	Quantity - 1 Weight - 3kg Size (cm) - 50 x 25 x 10	
Lever action 205/60 Litre Drum Pump HK22	Versatile lever action drum pump suited to low and medium viscosity oils. 1/2 Litre per stroke ideal for filling oil bottles.	Quantity - 1 Weight - 3kg Size (cm) - 46 x 20 x 10	
Lever action 205 Litre Multi Ratio Gear Oil pump 30200	RAASM multi ratio gear oil pump has adjustable length lever to increase pressure on down stroke making viscous gear oils easier to pump. Four settings delivering from 220 mls per stroke at 1.5:1 for SAE 80W90 gear oils down to 100 mls per stroke at 6.9:1 for SAE 250 gear oils. Pump includes adjustable suction spear for 60/205 Litre drums, metal drum bung adaptor, 2 metre delivery hose and end of hose ball cock with convenient hooked extension.	Quantity - 1 Weight - 5kg Size (cm) - 64 x 51 x 90	
Polypropylene Syphon Pump PP25	Convenient and economical syphon pump for 205 Litre drums. Suitable for coolants and other non-solvent fluids, it delivers up to 20 LPM.	Quantity - 1 Weight - 1kg Size (cm) - 120x 12 x 12	
Rotary 205 Litre Oil and Chemical Pump RP90R	Rotary vane oil pump in chemical resistant Ryton, and stainless steel with Teflon seals. Suitable for handling a variety of aggressive chemicals. Chemical compatibility chart is available on request.	Quantity - 1 Weight - 3kg Size (cm) - 40 x 15 x 15	
Rotary 205 Litre Oil Pumps SK778 SB25	Rotary vane oil pumps. Pump and syphon in both directions. Deliver approximately 300mls per revolution or 20 lpm. Adjustable height bung adaptor suits 60 and 205 Litre drums. SK778 features durable lightweight cast alloy construction while SB25 has heavy duty cast iron body.	Quantity - 1 Weight - 6kg Size (cm) - 100 x 18 x 18	
Rotary 205 Litre Diesel Fuel pumps TEC50032 LP32	High volume rotary drum pumps suited to transfer of diesel, oil and coolant at approximately 1 Litre per revolution. Adjustable height bung adaptor suits 60 and 205 Litre drums. Fuel transfer accessories including heavy duty bung adaptor, hose kit and fuel filter available. TEC50032 features durable alloy construction. LP32 features heavy duty oil filled gearbox.	Quantity - 1 Weight - 7kg Size (cm) - 100 x 30 x 15	
TEC50032H	High volume rotary drum pumps suited to transfer of diesel, oil and coolant at approximately 1 Litre per revolution. Adjustable height bung adaptor suits 60 and 205 Litre drums. Fuel transfer accessories including heavy duty bung adaptor, hose kit and fuel filter available. TEC50032 features durable alloy construction. LP32 features heavy duty oil filled gearbox. With nozzle, holster & hose.	Quantity - 1 Weight - 8Kg Size (cm) - 53 x 36 x 20	

Terms and Conditions Of Sale

All goods are supplied by Cooper Standard Automotive (Australia) Pty Ltd trading as Tecalemit, hereinafter referred to as the seller, on only the following terms and exclude any terms or conditions contained in documents submitted by the purchaser, unless specifically agreed in writing by the seller.

- 1. Specifications:** The seller reserves the right to make any alteration or improvement to, or departure from, any specification or design, at its discretion, unless otherwise agreed.
- 2. Prices:** List prices and delivery charges are based on current costs and are therefore subject to alteration without notice. Goods will be invoiced at the prices ruling at the date of delivery. Recommended Trade Pricelists are published from time to time and available on request.
- 3. Minimum Order:** Any order below \$100.00 will be subjected to a surcharge of \$15.00 to cover the cost of freight and administration.
- 4. Point of Delivery:** Prices quoted are Free into Store within metropolitan areas of Sydney, Melbourne, Brisbane, Adelaide and Perth for all orders over \$100.00 in value. Other areas all orders, freight cost to buyer account.
- 5. GST:** Prices quoted are exclusive of any GST (as that term is defined in the New Tax System (Goods and Services Tax) Act 1999 as amended ("GST Act"). If the goods and / or services being the subject of the quotation are a taxable supply for the purpose of the GST Act, in addition to paying for the goods and services, the purchaser must pay to the company the GST payable in respect of the taxable supply.
- 6. Insurance:** The goods will not be insured by the seller beyond the point of delivery. Insurance for loss or damage in transit beyond the point of delivery is the purchasers responsibility unless the seller is expressly instructed to effect insurance cover on behalf of the purchaser and at the purchasers cost.
- 7. Payment:** Standard trading terms are nett thirty (30) days to approved credit customers. i.e. Payment is required on or before the last working day of the month following month of invoice.
- 8. Cancellation:** An accepted order cannot be cancelled except by mutual consent of purchaser and seller. All cost incurred up to the date of cancellation including a 10% handling charge will be to the purchasers account.
- 9. Samples:** Cost of samples of specifically modified or developed products will be borne by company making the request and samples cannot be returned for credit.
- 10. Warranty:** (a) The seller warrant that the goods manufactured by it and bearing its identification will be of merchantable quality for a period of 12 months from the date of invoice and when used in conditions under which such goods are ordinarily used. If the goods are unmerchantable they will be repaired or replaced free of charge in return to the seller with the warranty period provided transportation charges are prepaid and inspection by the seller substantiates the claim being made. (b) Apart from this warranty the only conditions, warranties, liabilities to compensate or indemnify, representations and statements which are binding upon the seller in relation to its supply of goods are those expresses in writing by the seller or those otherwise required by law (including the Trade Practice Act, 1974) to be binding upon it and to the extent permitted by such laws the liability (if any) of the seller arising or resulting from such conditions, warranties, liabilities to compensate or indemnify, representations and statements shall at the seller's option be limited to any of the following: the replacement of the goods or the supply of equivalent goods; the payment of the cost replacing the goods, or acquiring equivalent goods or of having goods repaired; and otherwise all conditions and warranties whether express in implied by law and all representations, statements and obligations which would otherwise be binding upon the seller are hereby expressly excluded. Except to the extent provided for immediately above the seller shall have no liability (including liability for negligence) to any person for any loss or damage consequential or otherwise howsoever suffered or incurred by any such person in relation to the goods and without limiting that generally in particular any loss or damage consequential or otherwise howsoever suffered or incurred by any such person caused by or resulting directly from the goods or from any failure, breakdown, defect or deficiency whatsoever nature and kind of or in the goods. (c) The seller does not promise that facilities for repair of the goods or parts will be available. (d) Specific product and extended warranties may apply to individual products, details of which are available on request.
- 11. Return of Goods:** Goods returned for credit will only be accepted up to fourteen (14) days from date to despatch provided authorisation is obtained and the goods are received in 'as new' condition. All freight charges to customer account. Credit will be allowed after 15% is deducted for handling. Merchandise returned because of errors or other deficiencies on the part of the seller will be replaced at no charge or full credit allowed after the return of same. Non-standard products are non-returnable.
- 12. Time of Delivery:** Every endeavour will be made by the seller to comply with the estimated delivery, but in no case will the seller be liable for loss or damage howsoever caused by delivery.
- 13. Standard Packs:** Where possible we supply stock item in standard packs. This will assist your warehouse operation and reduce handling cost; therefore we ask you cooperation by ordering in standard pack quantities.
- 14. Retention of Title:** The customer shall be responsible at all times for maintaining the company's property, title of which shall not pass until payment, if made by cheque, has been cleared by the bank on which it is drawn. Furthermore, the customer hereby authorises the company to repossess the goods if, in the sole opinion of the company, the payment of any amount in respect of goods supplied by the company is in jeopardy.

WWW.TECALEMIT.com.au



TECALEMIT

To obtain more information on Tecalemit automotive workshop and lubrication equipment solutions contact Tecalemit.

Tecalemit : A Division Of Cooper - Standard Automotive (Australia) Pty Ltd

Head Office
6 Sheffield Street
Woodville North
South Australia 5102

General Enquiries
Ph: 1800 68 55 77
Fax: 1800 68 55 33
Email: sales@tecalemmit.com.au

Customer Services
Freecall within Australia: 1800 68 55 77
expertadvice@tecalemmit.com.au
www.tecalemmit.com.au

